

ASSEMBLY INSTRUCTIONS PAGE 1
(ASSEMBLE ON A LEVEL, CLEAN SURFACE)

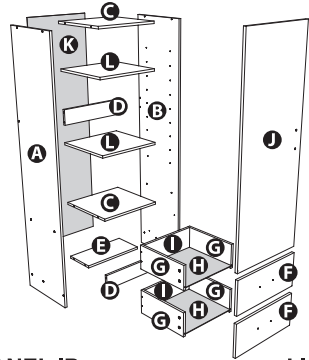

IMPORTANT

WHEN THE THIN EDGE OF A PANEL FACES FORWARD IN A UNIT, THAT EDGE SHOULD ALWAYS BE WHITE



- PANEL ID:**
- A** - LEFT SIDE (X1)
 - B** - RIGHT SIDE (X1)
 - C** - FIXED SHELF (X2)
 - D** - CROSS BRACE (X2)
 - E** - HALF HORIZONTAL (X1)
 - F** - DRAWER FRONT (X2)
 - G** - DRAWER SIDE (X4)
 - H** - DRAWER BASE (x2)
 - I** - DRAWER BACK (X2)
 - J** - DOOR (X1)
 - K** - BACKBOARD (X1)
 - L** - ADJUSTABLE SHELF (X2)

LIST OF PARTS:

No	DIAGRAM / DESCRIPTION	Qty
1	UNITAR SCREW (M7 x 40mm)	16
2	ALLEN KEY 'Z'	1
3	MOONSHAPE METAL HANDLE SCREW (M4 x 18mm)	3
4	METAL DOOR HINGE	2 SETS
5	SCREW (M3.5 x 14mm)	30
6	CAM	8
7	MINIFIX	8
8	WOOD DOWEL (M8 x 40mm)	4
9	NAIL LEG STUD	4
10	NAIL	40
11	UNITAR SCREW CAP	16
12	ADJUSTABLE SHELF SUPPORT	8
13	ANTI-TIP BRACKET (PVC)	1
14	WALL PLUG	2
15	SCREW (M3.5 x 35mm)	10
16	DRAWER SLIDE (CR) x2 DRAWER SLIDE (DR) x2 DRAWER SLIDE (CL) x2 DRAWER SLIDE (DL) x2	8 TOTAL RAILS

*Hammer/Screwdriver not included

WHITE MATT FINISH

1650mm H 450mm W 410mm D

CARE CAUTION: TO CLEAN PARTICLE BOARD WITH MELAMINE FINISH, PLEASE CLEAN WITH A SOFT, DRY CLOTH. DO NOT USE CHEMICALS OR DETERGENTS AND AVOID WATER AND DIRECT SUNLIGHT.

WARNING: Tip-over hazard.



WARNING: It is **STRONGLY RECOMMENDED** that you **ANCHOR** this product installing the **ANTI-TIP BRACKET** and **SCREWS** (Step 9) and **ATTACHING** the **1 Door / 2 Drawers Unit** to a **SOLID, FLAT WALL**.

DANGER: TOPPLING FURNITURE CAN CAUSE SERIOUS INJURIES AND DEATH.

IMPORTANT: Regularly check that Anti-Tip Bracket and Screws are securely maintained. Stability of tall items may be affected by thick carpets and uneven floors, or uneven and unstable walls.

SAFETY: Carefully check for any electrical wires or plumbing inside the wall before drilling any holes. (If unsure, contact a qualified Tradesman).

Walls are constructed from different materials (i.e: Masonry = Solid Wall, Plasterboard = Hollow Wall) so it is important to use appropriate wall fixings and screws for your wall type. Your local Hardware Store will stock the necessary extra screws, drill bits and fixings, and can offer suitable advice if needed. **DO NOT** place TV Sets or other heavy objects on top of this Unit. **DO NOT** overload the shelves of this Unit. **NEVER** allow children or adults to climb or hang on this Unit.

PANEL INFO:

A LEFT SIDE (X1) NOTE: HINGE HOLES 1650 mm INSIDE VIEW 380 mm	B RIGHT SIDE (X1) 1650 mm INSIDE VIEW 380 mm	C FIXED SHELF (X2) NOTE: ONE LAMINATED EDGE 390 mm x 420 mm	D CROSS BRACE (X2) 100 mm x 420 mm	E HALF HORIZONTAL (X1) NOTE: ONE LAMINATED EDGE 200 mm x 420 mm	F DRAWER FRONT (X2) 196 mm x 446 mm INSIDE VIEW
G DRAWER SIDE (X4) 150 mm x 350 mm	H DRAWER BASE (x2) *3mm thick 375 mm x 345 mm	I DRAWER BACK (X2) 150 mm x 365 mm	J DOOR (X1) 1160 mm x 448 mm NOTE: LARGE HINGE HOLES INSIDE VIEW	K BACKBOARD (X1) 1565 mm x 450 mm *3mm thick	L ADJUSTABLE SHELF (X2) NOTE: LAMINATED ALL EDGES 370 mm x 420 mm

ASSEMBLY:

8/22

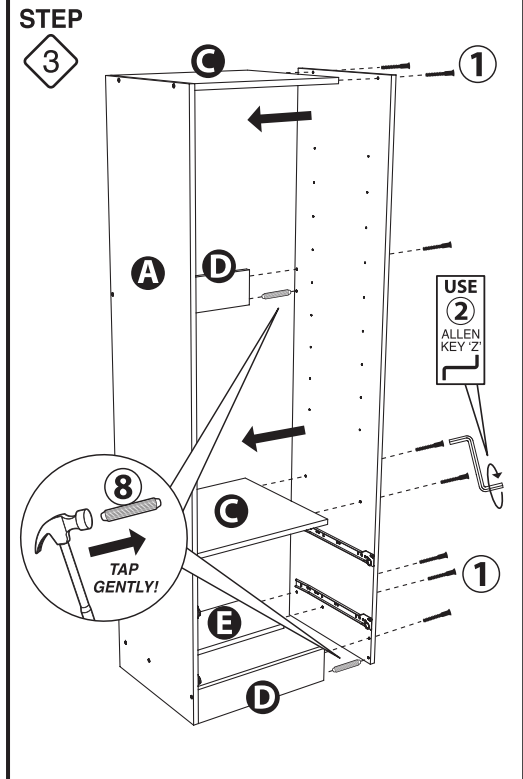
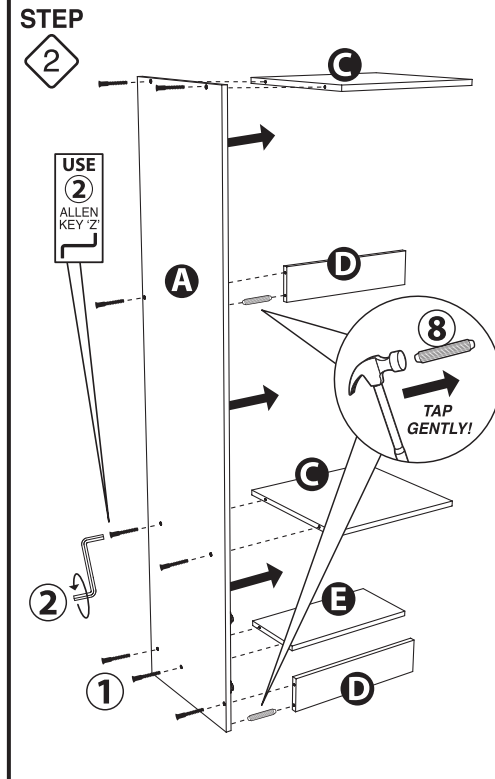
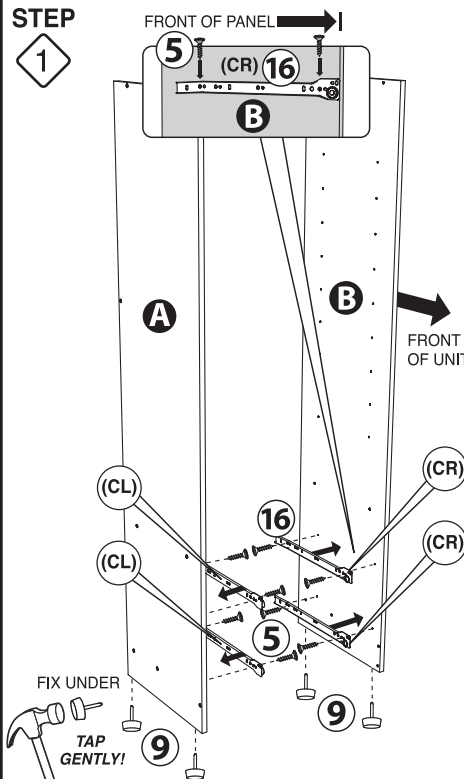

Free Standing
1650mm High
1 Door/2 Drawers Unit

ASSEMBLY INSTRUCTIONS PAGE 2
(ASSEMBLE ON A LEVEL, CLEAN SURFACE)

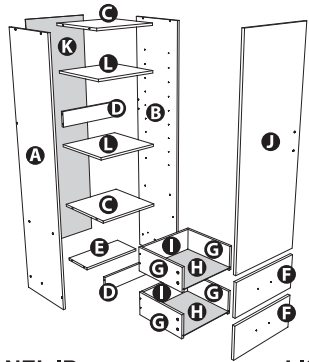

IMPORTANT
WHEN THE THIN EDGE OF A PANEL FACES FORWARD IN A UNIT, THAT EDGE SHOULD ALWAYS BE WHITE

TWO PERSON ASSEMBLY RECOMMENDED

- PANEL ID:**
- A** - LEFT SIDE (X1)
 - B** - RIGHT SIDE (X1)
 - C** - FIXED SHELF (X2)
 - D** - CROSS BRACE (X2)
 - E** - HALF HORIZONTAL (X1)
 - F** - DRAWER FRONT (X2)
 - G** - DRAWER SIDE (X4)
 - H** - DRAWER BASE (x2)
 - I** - DRAWER BACK (X2)
 - J** - DOOR (X1)
 - K** - BACKBOARD (X1)
 - L** - ADJUSTABLE SHELF (X2)

LIST OF PARTS:

No	DIAGRAM / DESCRIPTION	Qty
1	UNITAR SCREW (M7 x 40mm)	16
2	ALLEN KEY 'Z'	1
3	MOONSHAPED METAL HANDLE SCREW (M4 x 18mm)	3
4	METAL DOOR HINGE	2 SETS
5	SCREW (M3,5 x 14mm)	30
6	CAM	8
7	MINIFIX	8
8	WOOD DOWEL (M8 x 40mm)	4
9	NAIL LEG STUD	4
10	NAIL	40
11	UNITAR SCREW CAP	16
12	ADJUSTABLE SHELF SUPPORT	8
13	ANTI-TIP BRACKET (PVC)	1
14	WALL PLUG	2
15	SCREW (M3.5 x 35mm)	10
16	DRAWER SLIDE (CR) x2	8
	DRAWER SLIDE (DR) x2	
	DRAWER SLIDE (CL) x2	
	DRAWER SLIDE (DL) x2	

TOTAL RAILS

*Hammer/Screwdriver not included

ASSEMBLY: (cont)

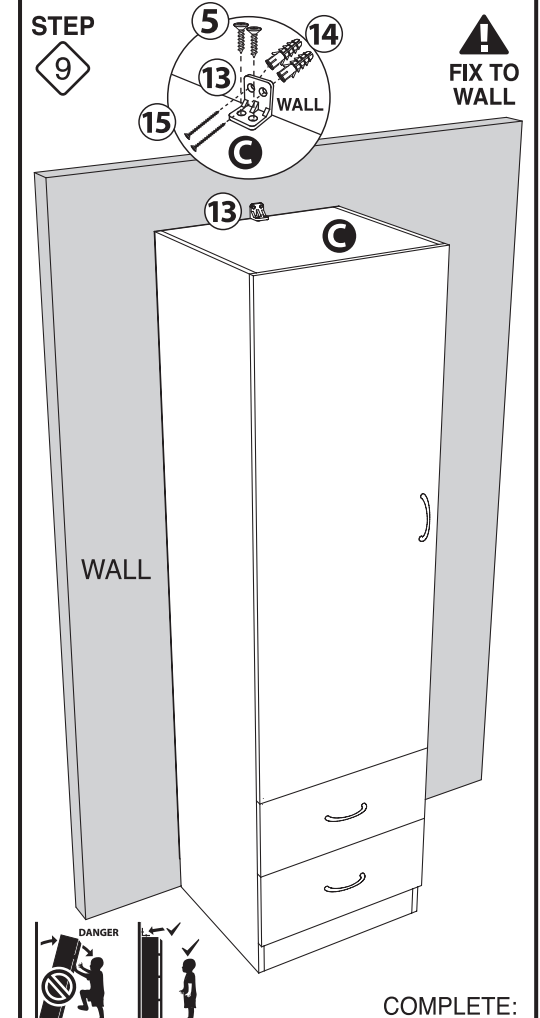
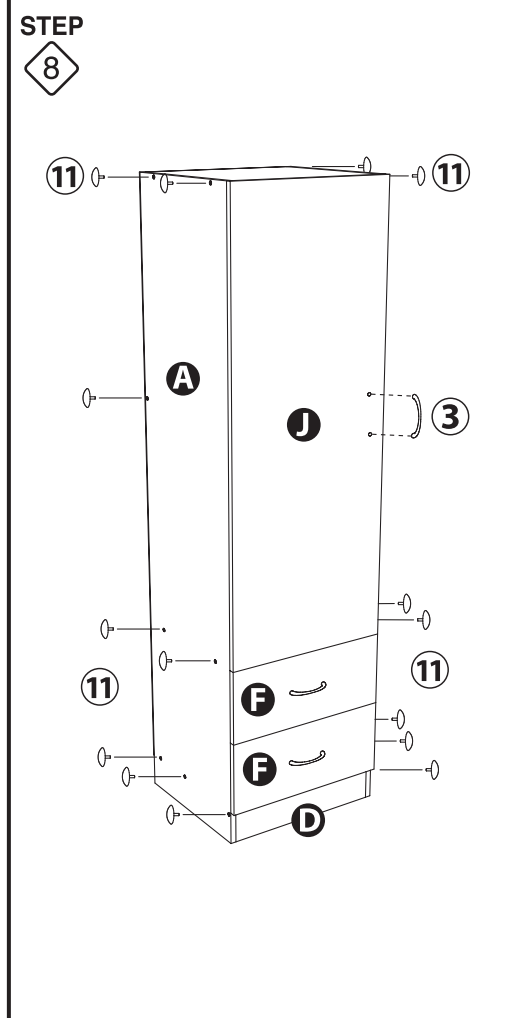
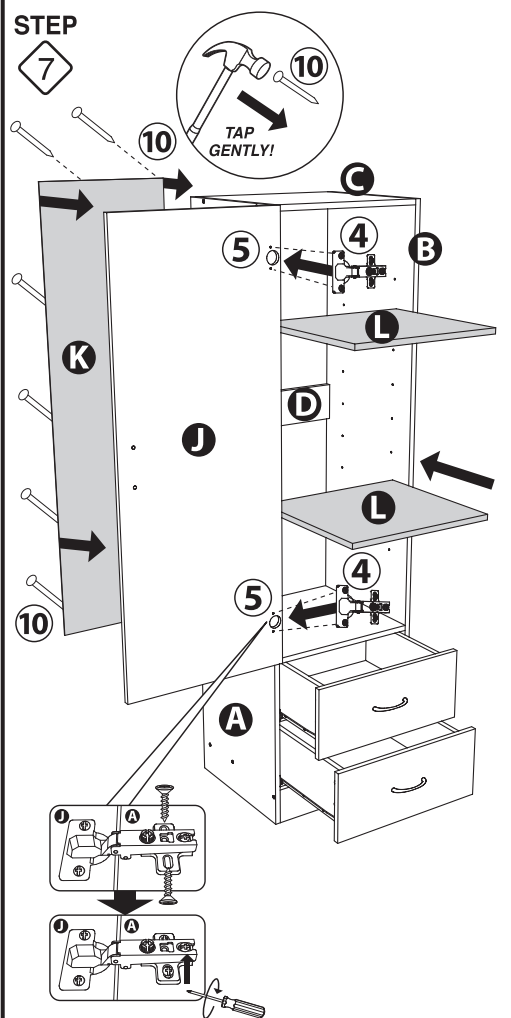
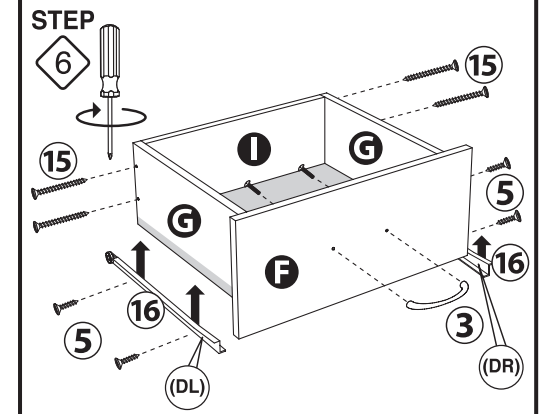
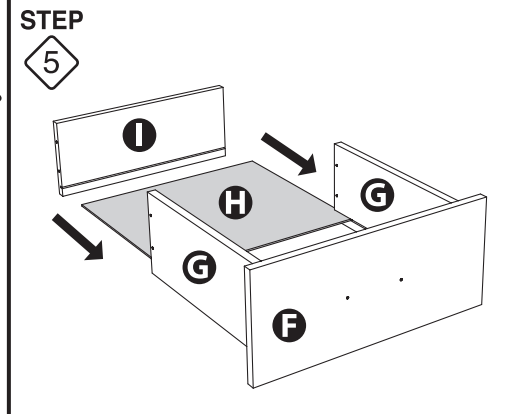
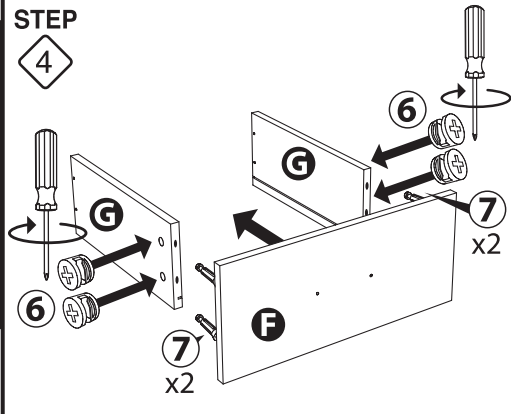

COMPLETE: